



Special Issue of Second International Conference on Advancements in Research and Development (ICARD 2021)

Implementation of Smart Helmet for Bikers

Neelam Yadav¹, Sunil K. Singh²

¹DAVCET, Kanina, Haryana, India

²CCET (Degree Wing), Chandigarh, India

neeluyadav2008@gmail.com¹

Abstract

In this research work, major concern is Safety and Security. Road accident cases due to drinking and driving are increasing day by day and even with the advent of the technology, people are losing lives. To address this issue, A Smart Helmet is implemented which focus multiple safety and security issues. Our research work aims for Smart Helmet comprises of several features like Alcohol Detection, GPS Tracking, Helmet Wear – Removal Detection, Directional signal light indication and Bike ignition control.

Keywords: *Arduino IDE, Alcohol Detection, GPS Tracking, Directional signal light indication, Helmet wear and Removal Detection and Bike ignition control*

1. Introduction

Accidents are the major cause of human loss now-a-days. India stands in the seventh place in road accidents in Asia. The reasons might be like carelessness of the rider, carelessness of the neighbour vehicles, road pits, low lit streets, drunk & drive and much more, poor maintenance of the vehicles and many more. Recently world health organisation stated that in 2019-2020 year approximately 1.3 million people had died in the accidents. Most of the earlier researches had been proposed different methodologies for the Helmet in order to avoid the accidents. But most of the proposed methodologies are based on the GSM, GPS tracking system, so in this method when a person had had met with a accidents then the message and location would be sent to his family and local police station. Our research work mainly aims to avoid accidents so that if a person had wear this smart helmet then only the bike will be start otherwise it can't. In this paper a Helmet has been designed with several features other than GPS and GSM like Alcohol detection, Helmet Wear – Removal Detection, Directional signal light indication and Bike ignition control.

2. Literature Survey

Manjesh N and Prof.Sudarshan Raj [1] successfully proposed a smart head protector with the smart features like Alcoholic sensor, vibration sensor, pressure sensor, GPS tracking system. In this method when a person had met with an accident the Vibration Sensor sends the data to processor, then the processor had send the data to the local police station and to his family with the help of the GPS tracking system. SudharsanaVijayan et al [2] introduced a Smart Helmet with the help of the Gas sensor in the place of the "MQ-3" sensor. Manjesh N and Prof.Sudarshan Raj [3] introduced the system location where the accident has occurred. But limitation of project is, in some place where there is no network available then it is difficult to send the message. HajerSalim and Malathi B. N [4] designed Microcontroller 8051 based circuitry with RF link for its simple working and operation. The author had designed a smart Helmet with the RF transmitter and Receiver.in order to send the data or to Receive they have used a Amplitude shift keying at it has been working under the frequency of 435MHZ. It has drawback that bike

suddenly stops working when helmet keep out from head. Nitin Agarwal et al [5] integrated a smart head protector into three Modules namely Voice module, Helmet Module, Bike Module. Saravana Kumar K et al [6] introduced a system for the smart Helmet with the help of a RF Trans receiver. In all the earlier proposed methods the major limitations is, in some place where there is no network available then it is difficult to send the message.

3. Proposed System

An intelligent helmet is the suggested scheme. The system ensures the biker's safety by making it necessary to wear the helmet after meeting an accident, as per government guidelines, also to get proper and prompt medical care. A module is connected to the helmet, so the module synchronizes with the module attached to the bike. An RF Module acts as a wireless link which able to communicate between transmitter and receiver. The device will have the following features:

- It will ensure that the helmet is worn by the rider. The bike will not start if he fails to do so.
- It would also ensure that bikers do not drink alcohol. The bike will not start if the rider is intoxicated.

On the bike, an accident detection module will be mounted, which will be able to detect accidents and will be able to quickly inform the police control room of the accident, and if the accident is minor, the rider will abort the message by pressing the abort button.

It is going to consist of two parts:

- One Module on shield and helmet
- Another Module on the bike.

Data from the helmet can be transferred to the bike wirelessly. The micro-controller will determine the behaviour of other blocks according to the various sensor inputs. The main advantages are:

- Remote area injury detection can be quickly identified, and emergency care rendered in a short time.
- Immediately stops the bike by using an alcohol detector if the person is driving the bike while drinking. so that the risk of an accident will be diminished.
- Implement the whole circuit into tiny modules
- Less energy intensive security device.
- It can be used in the framework of real time protection.

The main limitations of the proposed system are:

- Even in areas where mobile network is lacking, the individual rides the bike, so GSM network is needed to send SMS.
- When the helmet is mistakenly thrown down, it is recognized as an accident by the machine.

4. Methodology and Implementation

An alcohol sensor and touch sensor attached to a controller. Alcohol sensor takes input from the exhalation of the rider. Touch sensor activates when the rider wears the helmet. These two signals pass through AND logic and is transmitted wirelessly to the controller equipped inside the vehicle. On receiving this signal, ignition system of the bike gets activated. Now when the rider inserts the key, bike starts his ride. When he approaches a turning on the road, the gyroscope sends the angle value based on bending of the bike to the helmet controller through the bike controller. If the values supplied by gyroscope lies in a certain range, the led indicators attached to the helmet turns on depending on the direction of the bike movement (left or right). Even when a biker applies a break, bike controller sends a signal to the helmet to active the red led indicator at the backside of the helmet. Attaching led indicators on the backside of the helmet assures safety of the rider because it additional alert apart from the bike indicators to the neighbouring vehicle and a rider can be easily spotted in dark nights also. The figure 1 Block diagram of Smart Helmet at Helmet Section and figure 2 shows Block diagram of Smart Helmet at Bike Section.

4.1 Software & hardware requirements

The following are software and hardware requirement for proposed helmet system:

Software requirement:

- Arduino IDE

Hardware requirements:

- Arduino UNO & NANO
- Full-face helmet
- Alcohol Sensor
- Relay
- Ultrasonic sensor
- Fingerprint sensor
- DPDT switches
- 8x8 led matrix
- GPS (Neo 6M)

- GSM (SIM 800L)
- RF TX & RX modules
- RF(Tx&Rx) with Encoder /Decoder

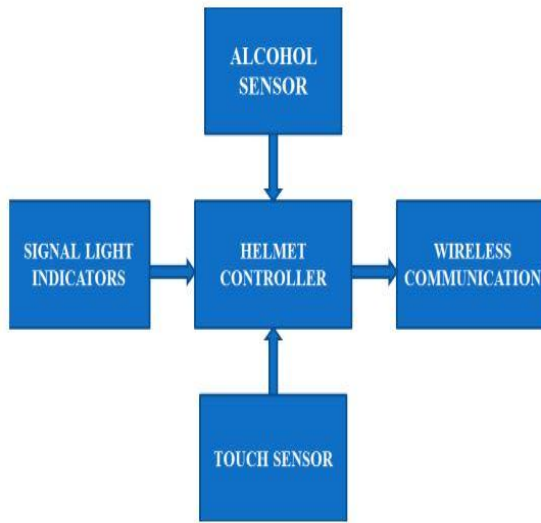

Fig.1 Block diagram of Smart Helmet at Helmet Section

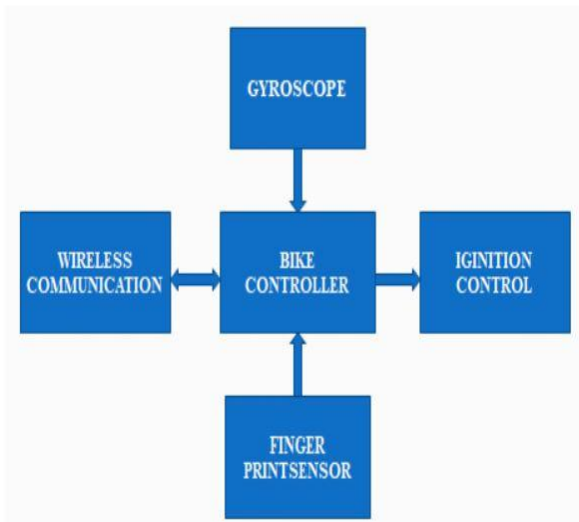

Fig.2 Block diagram of Smart Helmet at Bike Section

If both Alcohol and Touch Sensor Conditions are satisfied only then the bike will start. Also, if only a single condition is satisfied the engine won't start. When the rider approaches a turning then gyroscope sends the angle value based on bending of the bike to the helmet controller through the bike controller then the led indicators attached to the helmet turns ON. The figure 3 shows Schematic diagram of Smart Helmet at Bike Section and figure 4 shows Schematic diagram of Smart Helmet at Helmet Section.

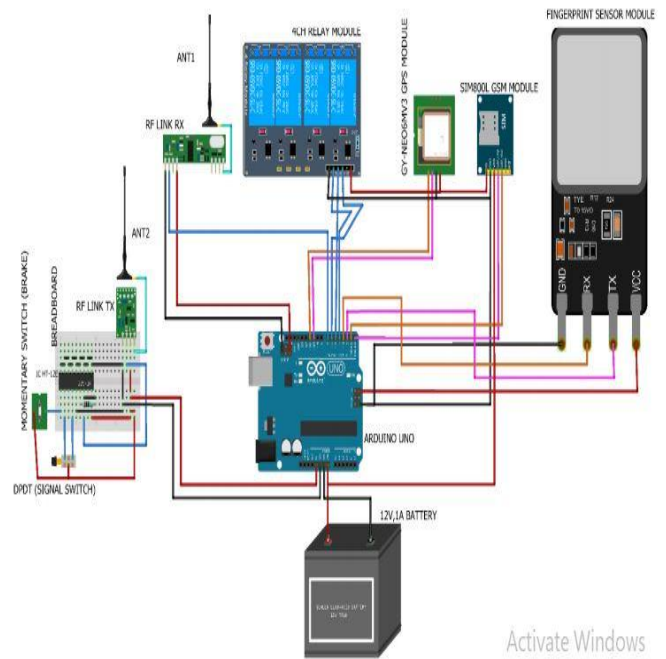

Fig.3 Schematic diagram of Smart Helmet at Bike Section

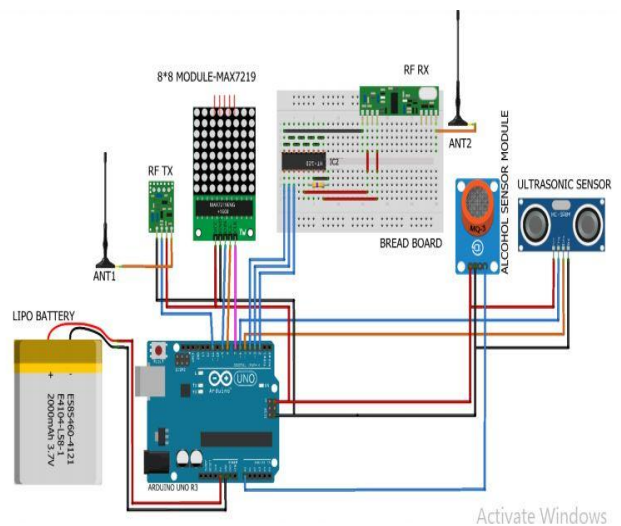

Fig.4 Schematic diagram of Smart Helmet at Helmet Section

The figure 5 shows flow chart shows the overall working principle of the “Design and Implementation of Smart Helmet for Improved Safety and Security”.

The Ultrasonic Sensor Interfacing With Arduino with following interconnections:

- Vcc to 5V Pin of the Arduino.
- Gnd to Gnd Pin of the Arduino
- Trig to Digital Pin 11
- Echo to Digital Pin 12

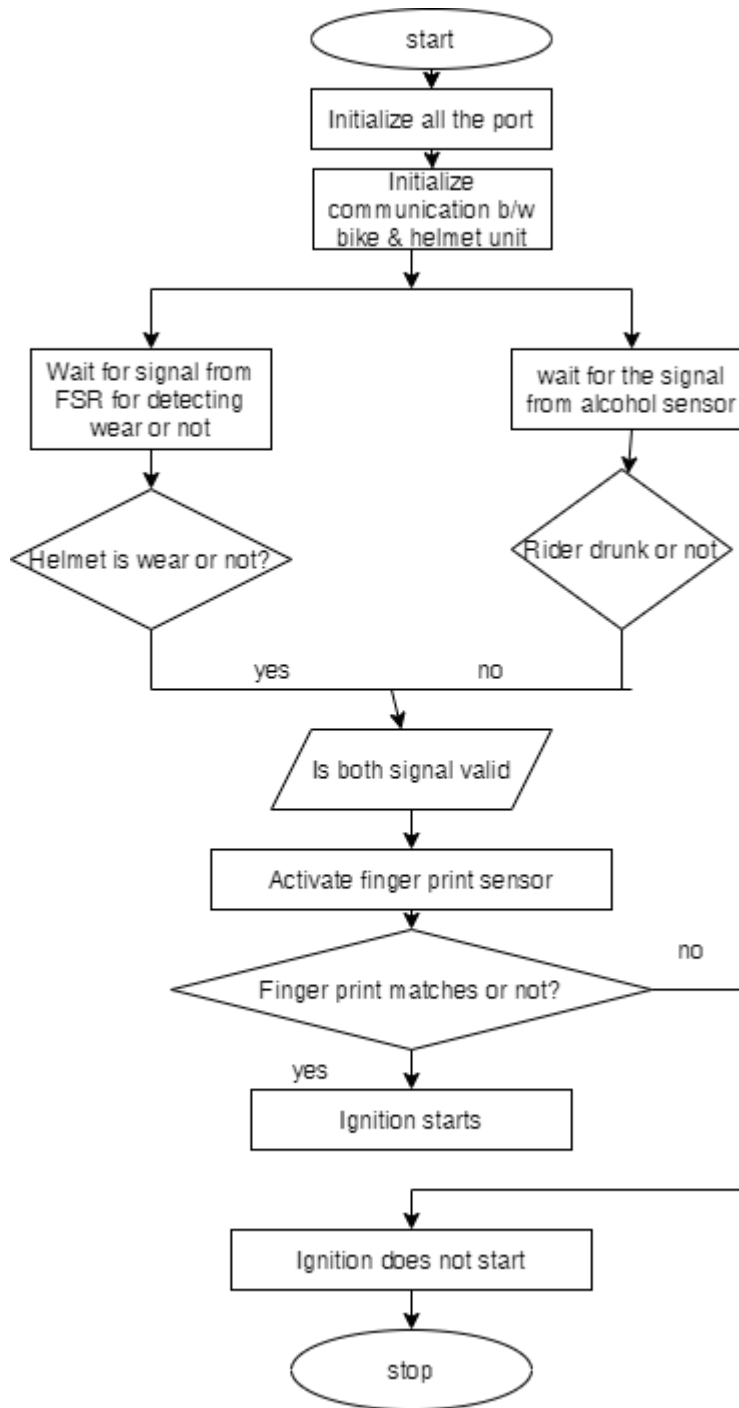

Fig.5 Flow chart representation of working of Smart Helmet

LPD433 (Low Power System 433 MHz) is a UHF band in which, in certain regions, license-free communication devices can operate. These frequencies correspond to the ITU region 1 of the 433,050 MHz to 434,790 MHz ISM band. The transmitter is mounted in the helmet and in the bike's receiver in the proposed system. The transmitter sends information as to whether or not the rider was wearing the helmet. After that the

receiver receives the information. The wiring for the transmitter is simple. It has only three connections. Connect the VCC pin to 5V pin and GND to ground on the Arduino. The Data In pin should be connected to Arduino's digital pin 12. The wiring is just as easy for the receiver as the transmitter was. Attach the VCC pin on the Arduino to the 5V pin and the GND to the ground. The digital pin 11 on the Arduino should be wired to either of the middle two Data Out pins. There are

4 leads for attaching the sensor. There are 2 of them for strength. The sensor's +5V terminal attaches to the Arduino Board's 5V terminal. The sensor's GND terminal attaches to an Arduino GND terminal. For the sensor, this establishes control. The other 2 interfaces are the sensor's analogue and digital output. These are connected to pin A0 analogue and pin D8 digital. LUX is a unique designed product for the bicycle. It is a gadget that can be hanged in the back position of the seat. It indicates if the cyclist is slowing down, turning left or turning right by using a matrix of LEDs (output). It is simple and intuitive for the other driver to understand the user's intention and also for the cyclist due to the whole system is automatic. The user doesn't have to press any button because it detects the inclination and the acceleration by a gyroscope and accelerometer integrated chip (input). This device is controlled by the Arduino code that we will define it and is powered by the battery. The fingerprint sensor we are using is an optical type, there are two more sensor types such as capacitive that can be found in smart phones and ultrasonic ones that are still in the test phase, and both of these options are costly, so for this hobby electronics and similar projects we will concentrate on this optical type. The way this optical fingerprint sensor works is that it takes an image of our finger ridges and then uses some algorithm to align with the same kind of data stored and presents the results.

Conclusions

The results of the proposed work conclude that, if the helmet is worn, the bike ignition will begin. So, the impact of an accident is naturally minimized. Both sensors in the device are coordinated by Arduino, i.e., Arduino Uno at the Bike Unit and Arduino Nano at the Helmet Unit. The RF module is designed to communicate wirelessly from the helmet unit to the bike unit, and a fingerprint sensor can prevent stolen bikes. As the future works, bioelectric sensors, small cameras on the helmet, can be introduced to measure Rider's various critical protection and security parameters.

References

[1] Manjesh N, Prof. Sudarshan Raj, "Smart Helmet Using GSM & GPS Technology for Accident Detection and Reporting System", International Journal of Electrical and

Electronics Research, Vol. 2, Issue 4, December 2014.

- [2] SudharsanaVijayan, Vineed T Govind, Merin Mathews, SimnaSurendran, Muhammed Sabah, "Alcohol detection using smart helmet system", IJETCSE, Volume 8 Issue 1, April 2014.
- [3] Manjesh N, Prof. Sudarshan Ra1, "Smart Helmet & Intelligent Bike System" International Research Journal of Engineering and Technology (IRJET) Volume: 03 Issue: 05, May-2016.
- [4] HajerSalim, Malathi B. N, "Accident notification system by using two modem GPS and GSM" International Journal of Applied Information Systems (IJ AIS) Foundation of Volume 8– No.3, February 2015.
- [5] Nitinagarwal, Anshulkumarsingh, Pushpendra \pratapsingh, Rajesh sahani "SMART HELMET" International Research Journal of Engineering and Technology (IRJET) e-issn: 2395 -0056 Volume 02, Issue 02, May 2015.
- [6] Saravana Kumar K, Anjana.B.S, Litto.Thomas, Rahul.K.V, "SMART HELMET", International Journal of Scientific & Engineering Research, Volume 7, Issue 3, March 2016.