



Special Issue of First International Conference on Management, Science and Technology (ICMST 2021)

Design of Real-Time Multi-Level Inverter with Remote Monitoring System

Ravindra Parab¹, Pawan Pandey²

¹Dept. Electrical and Electronics Engineering, Malwa Institute of Technology, Indore, India.

²Assistant Professor, Dept Electrical and Electronics Engineering, Malwa Institute of Technology, India.
Ravindra.parab.80@gmail.com¹

Abstract

This paper is about a single-phase multi-level inverter that uses DC source, multiple Monocrystalline photovoltaic cells to work. Initially, the simulation will be carried out using a Node MCU and an ATmega 328P to produce the low voltage control signals needed to operate the MOSFET Switching devices. Furthermore, the control signals will be activated by a NodeMCU, allowing the Inverter parameters and control signals to be visualized on the IoT Platform by projecting data to the cloud via ESP8266, allowing remote monitoring of the parameters following the Covid-19 pandemic. With Communication protocols and the use of an open-source framework (ThingsBoard), the user will be able to analyze & track; Study Multi-Level Inverter outputs in real time, allowing for improved performance and reduced E-Waste production.

Keywords: Multi-Level inverter, NodeMCU 8266, ATmega 328P, IOT, PZEM-004T, MOSFET, Wi-Fi, ESP32

1. Introduction

In today's multipurpose world, inverters have a variety of uses. They play an important role in ensuring a continuous supply of electricity, from factories to homes. When using traditional inverters, they are no longer capable of providing enough power because as the load increases, the inverters lose power and the Total Harmonic Distortion in the output increases. To compensate, we use a variety of capacitors and inductors, which tends to make the device bulky and inefficient in terms of cost. Furthermore, after the Covid19 Pandemic, troubleshooting and monitoring these devices' health and maintenance has become extremely difficult. As a result, the Cascaded H-Bridge multi-level inverter was introduced for a broader range of applications in the manufacturing, Electric automotive, aviation, and many other industries as a much more efficient source of electricity.[1-5].

This low-power Cascaded H-Bridge multi-level inverter is controlled by an Arduino or NodeMCU based circuit with IoT connectivity, displaying real-time data over the internet that can be accessed by the user from far-flung places, implying limitless possibilities for the next step of the digital revolution. The circuit consists of three different multi-level inverters i.e., 3, 5 and 7.

linked in series to add power linearly while lowering Total Harmonic Distortion for a stable output To improve the inverter's performance, it can run on a variety of power sources, including DC batteries, AC-DC transformers, and photovoltaic panels, making it entirely eco-friendly and therefore suitable for use in deserted areas.[6-10].

2. Objective

Prototype a smart Cascaded Multi-Level H-Bridge Inverter powered by Rectifier and fitted with IoT connectivity, allowing the user to remotely track inverter parameters and control signal levels

through the IoT platform (ThingSpeak), assisting in maintenance and life monitoring.

3. Proposed System

The main goal of the device design is to aid the user in determining the inverter's life cycle and operating levels. The system will use photovoltaic cells to capture solar energy and transform it to an alternating waveform using switching devices.

The Components used are

- NodeMCU
- PZEM-004T
- ATmega328
- MCT2E Optocoupler
- MOSFET IRFP9540
- MOSFET IRF540
- TIP 122
- TIP 127
- Transformer 0-12v 500ma
- Electrolytic Capacitor 1000uf
- DHT11
- LDR
- Solar panel

3.1DC Source

The prototype needs a DC source to function properly which in this case can be i) Mains AC to DC conversion ii) Solar PV cells (supporting green energy) or iii) A battery. When possible, only solar PV cells are used but when conditions are not suitable the prototype switches its DC source to one of the given sources using sensors (explained in system 2). The same happens when mains is not available or the battery is not capable to provide enough voltage. Further the prototype is divided into two systems.[11-15].

3.2System 1

The first part/system contains 3 H-bridges which help to provide different levels to the inverter when in a cascaded connection. The level of inverter is decided by the formula “2N+1” where N stands no. of H-bridges used. This in turn is connected ATmega328 (Arduino UNO) which gives timed control signals to enable or disable the switching devices as researched by S. Shuvo [1]. As the prototype consists of 3 H-bridges the system can provide the waveforms for 3-level, 5-level and a 7-level inverter which can be seen and verified by using and oscilloscope. This system would also be less complex and less costly as researches by T. Singaravel [2].

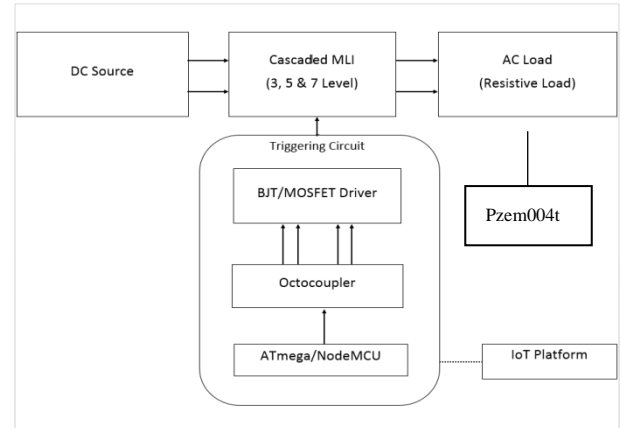

Fig.1. Block Diagram of Smart Multilevel Inverter

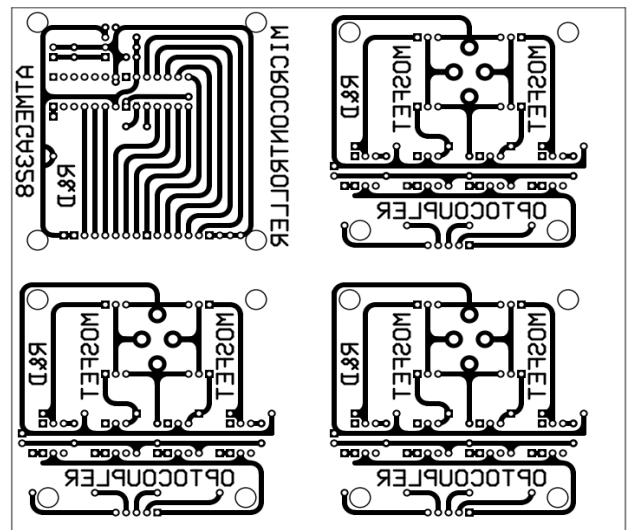

Fig. 2. PCB Design for ATmega 328P controlled Inverter

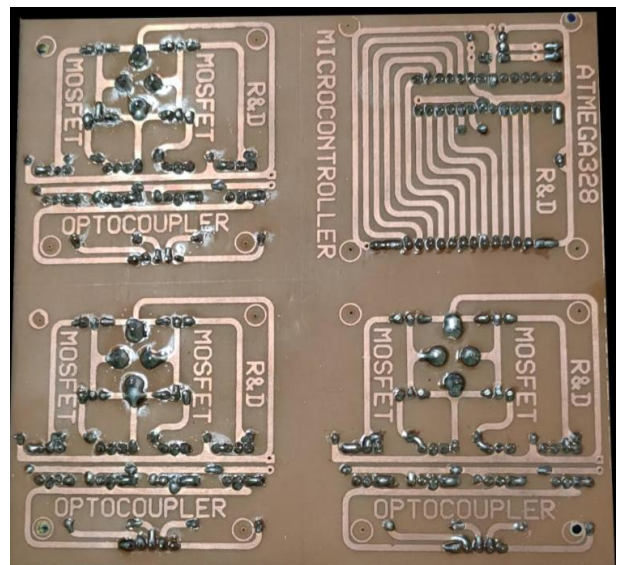

Fig.3. Fabricated PCB for ATmega 328P controller.

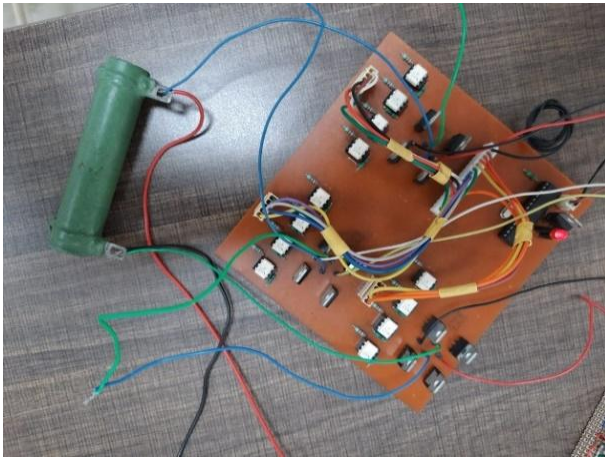

Fig.4. PCB with connected components and a test load of 500 ohms.

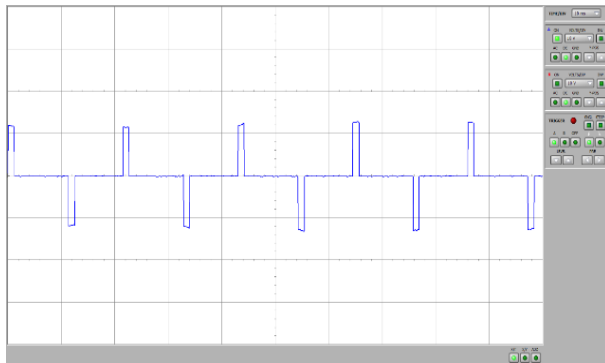

Fig.5. 3 level Sinusoidal Output

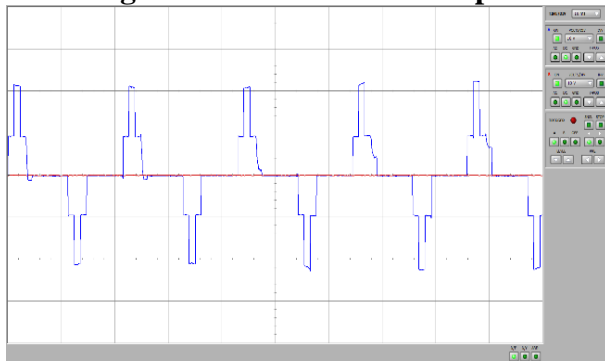

Fig.6. 5 level Sinusoidal Output

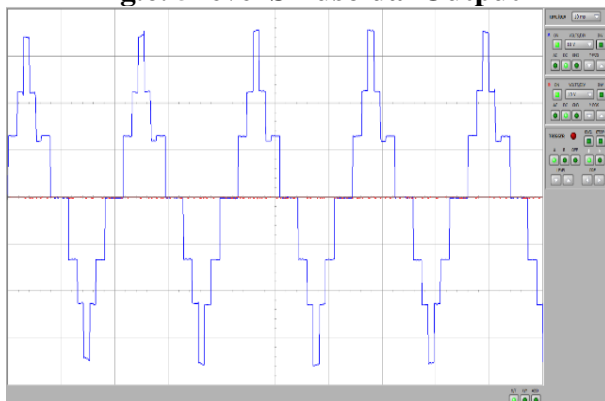

Fig.7. 7 level Sinusoidal Output

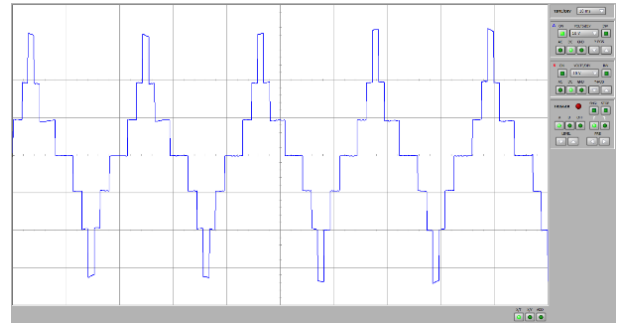

Fig.8. 7 level Sinusoidal Output with 500ohm Load

3.3 System 2

The second part/system contains an NodeMCU instead of an Arduino UNO to provide instant internet connectivity. The NodeMCU runs on ESP8266 firmware is connected to ThingsBoard (An open IOT platform) which runs on MQTT protocols. The NodeMCU is also connected with an LDR and dht11 (temperature and humidity sensor) for monitoring of conditions for shifting DC source for inverter. It also sends data for 3 level and 5 level inverters on the cloud platform where the waveforms can be seen remotely by the user.

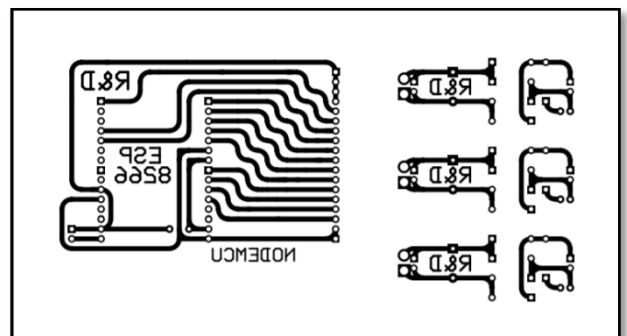

Fig. 9. PCB Design for NodeMCU controlled Inverter

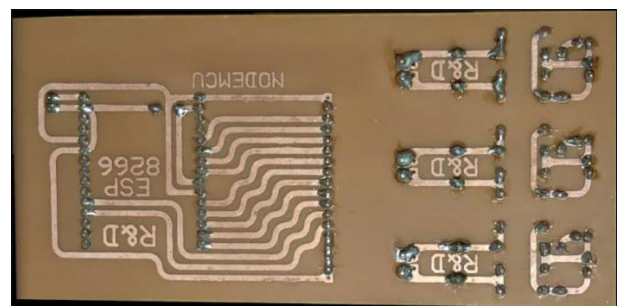

Fig. 10. Fabricated PCB for NodeMCU controller.

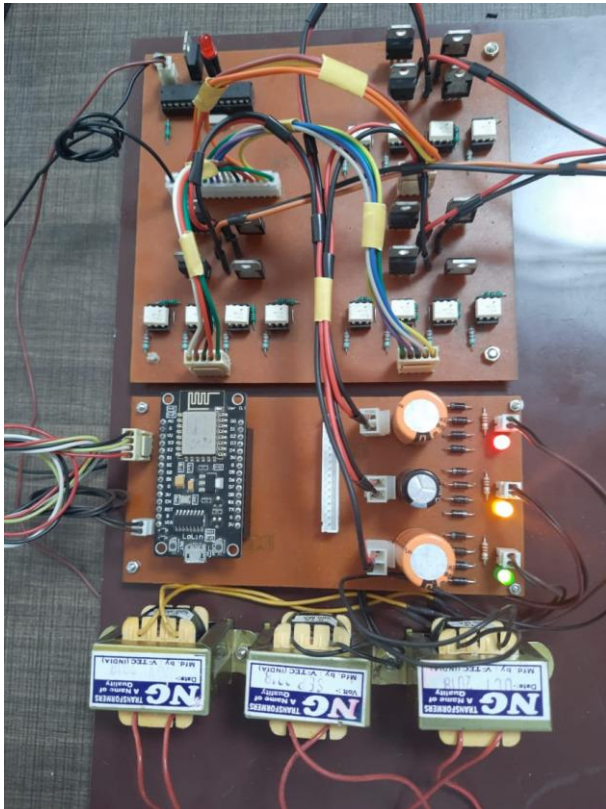

Fig. 11. PCB with connected components

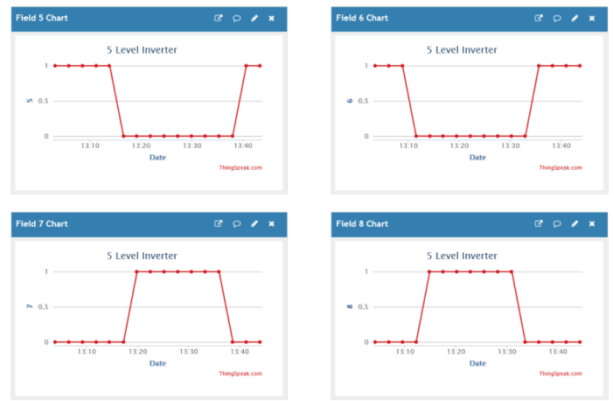

Fig. 14. 5 Level Inverter Control Signal Values

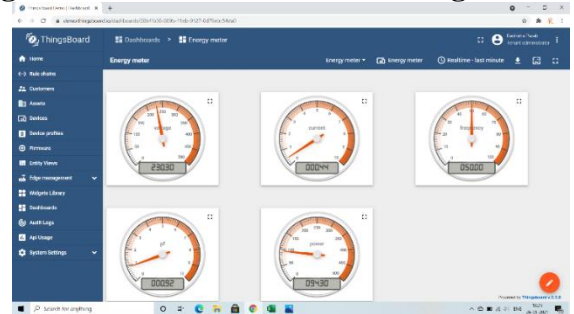

Fig. 15 things board dashboard

Conclusions

The two proposed models were prototyped using an AT mega 328p controller and another running on a NodeMCU. The output for 3,5 and 7 levels were verified on an oscilloscope for both systems. The following conclusions were noted:

- 1) Remote monitoring is feasible with a suitable IoT platform to observe the inverter control signals and other parameters such as its Temperature, Humidity or even Light intensity.
- 2) Both systems are cost effective for low to mid-range power outputs, with only the second system being a little complex to design than the other.
- 3) A drawback of the second system is a slight delay, which occurs when data is being transmitted to the IoT platform. This would result in a lower frequency of sinusoidal output as compared to the first system.

References

[1].A, RATHY G. Iot Based Smart Controlled Inverter. Apr. 2020, Iot Based Smart Controlled Inverter.



Fig. 12. 3 Level Inverter Control Signal Values



Fig. 13. 3 Level Inverter Control Signal Values

- [2].Bhatiya, Vinayak k, et al. "Implementation of Iot Based Monitoring and Controlling Solar System." International Journal of Innovative Technology and Exploring Engineering (IJITEE), Volume-9 Issue-5, Mar. 2020.
- [3].Bhumika V.N, Chethan N.P. "MONITORING OF IOT BASED SMART INVERTER USING RASPBERRY PI." International Journal of Emerging Technologies and Innovative Research JETIR, JETIR, Oct. 2020, www.jetir.org/view?paper=JETIREH06020.
- [4].Bilhan, AyseKocalmis, and SedatSunter. "Simulation and Design of Three-Level Cascaded Inverter Based on Soft Computing Method." Tehnički Vjesnik, Strojarški Fakultet u Slavonskom Brodu; Fakultet Elektrotehnike, Računarstvi i Informacijskih Tehnologija Osijek; Građevinski i Arhitektonski Fakultet Osijek, 15 Apr. 2020, hrcak.srce.hr/236799.
- [5].Menon, Gopal G, et al. "IoT Enabled Solar Smart Inverter." International Research Journal of Engineering and Technology (IRJET), Volume: 07 Issue: 04 | Apr 2020, 4 Apr. 2020.
- [6].Shuvo, Shuvangkar, and Eklas Hossain. "Design and Hardware Implementation Considerations of Modified Multilevel Cascaded H-Bridge Inverter for Photovoltaic System." IEEE Xplore, 24 Jan. 2019, ieeexplore.ieee.org/document/8625414.
- [7].Singaravelu, T. Design and Implementation of Seven Level Cascaded H-Bridge Inverter Using Low Frequency Transformer with Single DC Source. Apr. 2013,
- [8].MULTILEVEL INVERTER TOPOLOGY WITH REDUCED NUMBER OF SWITCHES M.Sandhiya¹, S.Meena², DR G. Mahesh Manivanna Kumar³
- [9].A Comparative Study of Multilevel Inverter Topologies AditayVardhan Singh¹, Ravi Shankar Singh²
- [10].Modified Cascaded H - Bridge Multilevel Inverter For Household Appliances P.Moses Stephen¹, M.Ponraj¹, N.Sathesh¹, K.Balamurugan¹, K.Karthikeyan²
- [11].Hardware Implementation of Multilevel DC-Link Inverter Supplying Resistive Load Nagisetty Sridhar.S¹, S. Annadurai*²
- [12].Design Of Five Level Inverter Fed Induction Motor Using Phase Shifted Carrier Pwm Technique Iyogesh S. Bais, 2 S.B.Deshpande, 3 S.P.Muley
- [13].Switched-Battery Boost-Multilevel Inverter with GA Optimized SHEPWM for Standalone Application Sze Sing Lee, Member, IEEE, Bing Chu, Nik Rumzi Nik Idris, Senior Member, IEEE, Hui Hwang Goh, Senior Member, IEEE, and YehEnHeng
- [14].Transistor Clamped H-Bridge Five-Level Multilevel Inverter for Photovoltaic Application – A Hardware Prototype Implementation Using Inverted Double Reference Single Carrier PWM Technique Mahajan SagarBhaskar 1, SanjeevikumarPadmanaban 1,*, FredeBlaabjerg 2, Anzari Mohammed
- [15].A Hybrid Cascaded multilevel inverter with diode assisted boosting network ; C.Bharatiraja, Aishwarya Ravi, Snachari Banerjee, Abhishek Chakraborty, AnirudhAnupam, Akshay Menon