



Voltage Enhancement In a Distribution Power System With SMES Based DVR

Bharath Kumar M¹, Dr.E.Latha Mercy Ph.D.MISTE²,

¹PG scholar, Department of Electrical and Electronics Engineering & Government College of Technology Coimbatore, Tamilnadu, India

²Professor and Head, Department of Electrical and Electronics Engineering & Government College of Technology Coimbatore, Tamilnadu, India

Abstract

This Power quality is one of the major concerns in the present power system environment. The situations like, voltage dip/sag, swells, harmonic content, etc. and their major effects on greatly susceptible loads are well known. To tackle these situations, custom power equipment are utilized. In this work, Proportional Integral (PI) control technique based Dynamic Voltage Restorer (DVR) is implemented in power distribution system to suppress voltage sag and swell under linear and non-linear load conditions. In conventional method, DVR is proposed to mitigate the voltage sag. But, presence of voltage swell may cause variation in output. In the proposed system, DVR with PI control technique is implemented which compensates both sag and swell. Using the program MATLAB 2014a, the design of the Superconducting Magnetic Energy Storage (SMES) module as a dc voltage source for minimizing voltage sag and improving the power efficiency of a DVR-based distribution system was presented. The simulation results show that the SMES-based DVR easily compensates both sag and swell and provides excellent voltage control in balanced and unbalanced situations.

Keywords: Dynamic Voltage Restorer (DVR), Power Conditioning Network (PCN), Superconducting Fault Current Limiter (SFCL) voltage sags and swell.

1. Introduction To Power Quality

Some of the usual perturbations in Power Quality (PQ) in the delivery network are voltage sags, voltage swells, interruptions, phase changes, harmonics and transients. Owing to sensitive loads at the distribution network, the most serious problem is considered among the disturbances voltage sag. Some of the tools are available to counteract, such as STATCOM, tap adjusting transformer, UPFC and DVR is available to alleviate issues with the voltage sag. Of these, the dynamic voltage restorer can offer the most commercial solution by injecting voltage as well as power into the device to reduce voltage sag. Dynamic Voltage Restorer (DVR) is a series-based

power electronics tool that can rapidly reduce the system's voltage drop and restore the load voltage to the pre-fault value. In series the DVR injects three single phase voltages with incoming voltages of supply. The magnitude and angle of phase of the voltage injected may differ depending on the parameters of the sag. The voltage injection allows actual and reactive variable exchange of power between the DVR and the responsive load or the distribution network. The voltage disturbance type, the safe load, and the magnitude and direction of the injected voltage depend on the amount of real and reactive power supplied by the DVR. Within the DVR the reactive power can be produced internally while storing energy is necessary to supply the real power.[1-4]

2. Dynamic voltage restorer

A Dynamic Voltage Restorer (DVR) is a power-based electronic converter equipment built to ensure the discriminating burdens from any other confounding forces on the supply side other than shortcomings. It is mainly attached to the distribution feeder for routine coupling purposes. The DVR is a collection of electronic power linked devices that are used to inject voltage of appropriate magnitude and frequency. The basic form of a DVR is shown in Fig.1. It has the following ingredients-

- Voltage Inverter Connection • DC Storage Unit
- Circuit filter • Transformer series

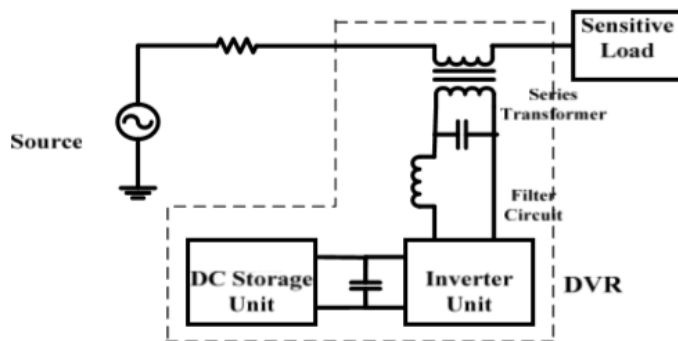

Fig.1 Structure of DVR

2.1 Principle of Dynamic Voltage Restorer

The DVR's key function is to inject voltage of the necessary magnitude and frequency if the power system network so desires. The DVR will be in stand-by mode, during the conventional service. The nominal or rated voltage is compared to the voltage variation during disruptions within the device and thus the DVR injects the difference voltage provided by the load. The analogous circuit of a DVR connected to the power grid is shown in Fig.2. This is the voltage of supply, the voltage applied by the DVR and the voltage of charge. 92 per cent of industrial plant interruptions are caused by voltage decreases. In order to address this deficiency, SMES-based DVR has been used to boost the power system efficiency due to its high power rating with maximum efficiency. Better performance of any other power storage unit. In this article, as the DVR energy storage unit, it suggests an excellent conductive magnetic energy storage unit. Dynamic Voltage

Restorer (DVR) is one of the popular custom power tools that can be used to increase the quality of power from any disturbances in the distribution network. The DVR is also used to secure and recover, or to restore the voltage level to the sensitive load. A collection of three phase voltages with a reasonable magnitude and length is always injected through the injection transformer and must be in the grid voltage range. A DVR may be a solid state power electronic switching system consisting of either GTO or IGBT, a condenser bank as an energy storage device, and transformers for injection.

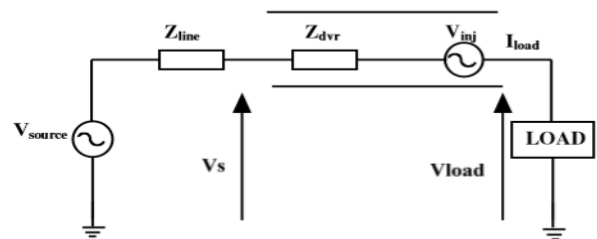

Fig.2. The Equivalent Circuit Of DVR

2.2 Compensation Techniques

There are four different methods of DVR voltage injection which are as follows:

- I) Pre-sag form of compensation
- II) In-phase compensation
- III) Advanced compensation method
- IV) Voltage tolerance method

3. Energy Storage Device

Energy storage for electricity is extremely important as it improves the way energy is produced, distributed and consumed. Energy storage helps in emergencies including power outages triggered by natural calamities, system failures, accidents etc. It is very difficult to immediately align the power supply needs with the demand within milliseconds. That makes power grids more robust and more effective. Excess energy storage requires further development and advancement to meet the ever-increasing rates of primary energy generated from renewable sources. The implementation of environmentally friendly policies to minimize greenhouse gas emissions and

improve protection of supply of energy strongly impacts the laws of the market today. All of these factors have contributed to the discovery of renewable energy sources, their use to meet the ever-increasing demand for energy and the storage of electricity. [5-8]

3.1 Superconducting magnetic energy storage

Within no time charging and discharge times have SMES systems which make them an attractive energy storage system for mitigation of sag. The advantage of SMES systems is that because of the superconducting properties, very small losses. This consists of superconducting magnetic energy storage unit, condenser stack, VSI, low pass filter and transformer for induction of voltage. This consists of a principal structure and its sub systems. The superconducting coil is the essential portion of the SMES system which is positioned in a cryostat or Dewar composed of a vacuum vessel and a liquid vessel. Liquid vessel maintains system temperature by having sufficient cryogenic system setup for cooling, and also holds temperature below critical temperature. Finally a transformer which connects and coordinates the power system and co-ordination of PCN operating voltage will reduce to acceptable levels.

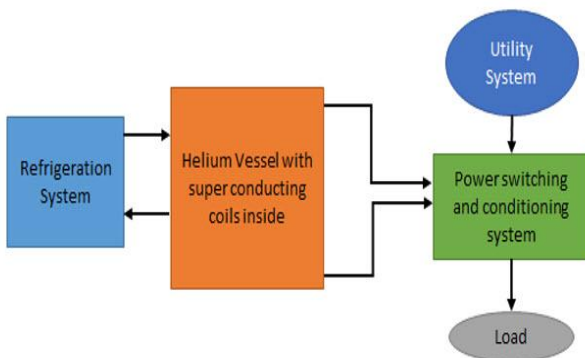

Fig.3. Structure Of SMES

4. Fault Current Limiter

Superconducting Fault Current Limiter (SFCL) is an advanced electrical device that has the ability to reduce the current level of faults during the first fault current cycle. The introduction of the Fault Current Limiter (FCL) can not only minimize the burden on network equipment but would also provide a link to improve the power system's reliability. There are various kinds of FCLs, constructed from various superconducting

materials and have different designs. These are divided into three specific types: the resistive type, the inductive type, and the SFCL style bridge. Yet with the expansion of power systems, the degree of short-circuit power system capability and short-circuit current faults is rising. If the amount of the local power system short circuit current exceeds the capacity of the operating equipment, the power grid and the health of the electrical equipment are seriously threatened.

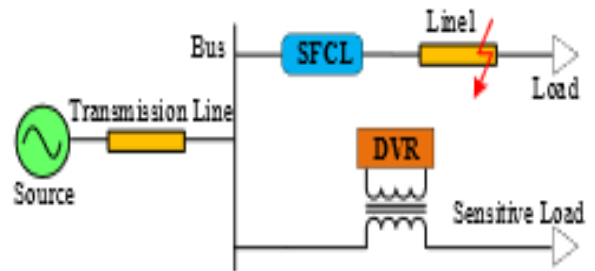

Fig 4. Shows the Block Diagram of DVR With SFCL

5. Simulation And Results

There are several methods for reducing the stress sag and swell. Between them the best way to control the voltage is to use a system at the point of interest. The instruments used for this purpose are already mentioned in the preceding chapter along with their control techniques. In MATLAB SIMULINK, these control strategies are simulated. This chapter presents the simulation results, and makes a comparative analysis based on their performance.

5.1 IMPLEMENTATION

A MATLAB simulation is performed to validate the proposed technique for implementing SMES based DVR. A MATLAB simulation is performed for research purposes in following steps.

Step1. Due to a fault in the transmission line without SMES dependent DVR, the voltage sag and swell is caused.

Step2. Implementation of DVR built on SMES.

Step3. Compensation of voltage sag and swell for different forms of fault use DVR based on SMES

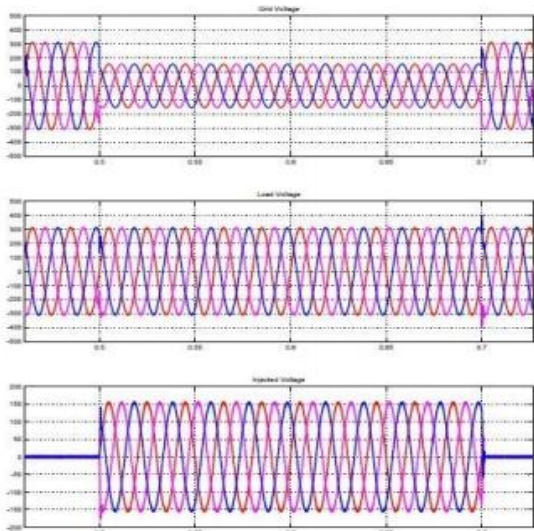

Fig5.Results of voltage sag compensation using DVR

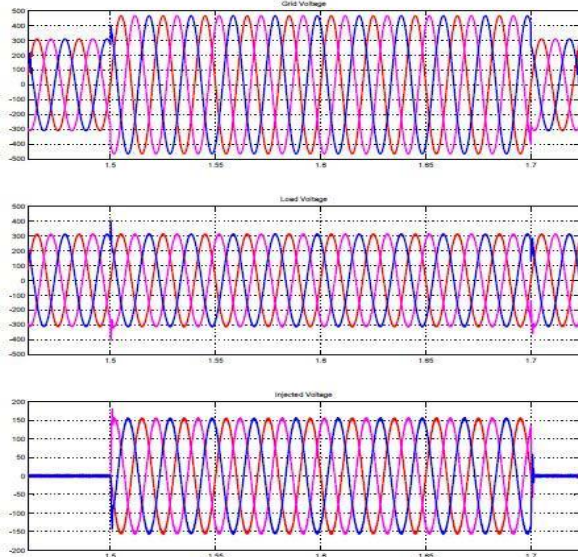

Fig.6.Results of voltage swell compensation using DVR

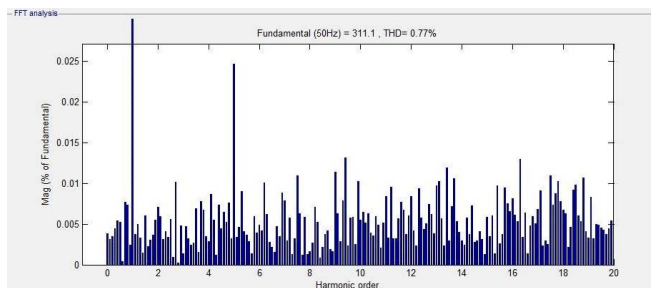

Fig7. THD of load voltage

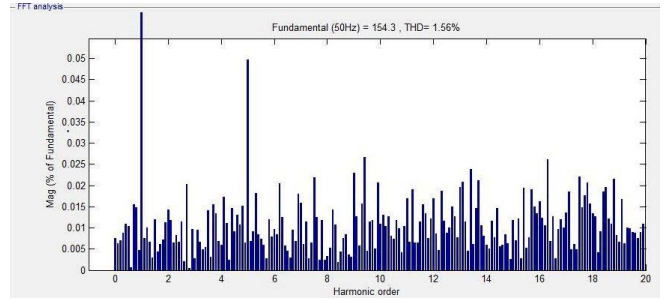

Fig.8.THD of Injected Voltage

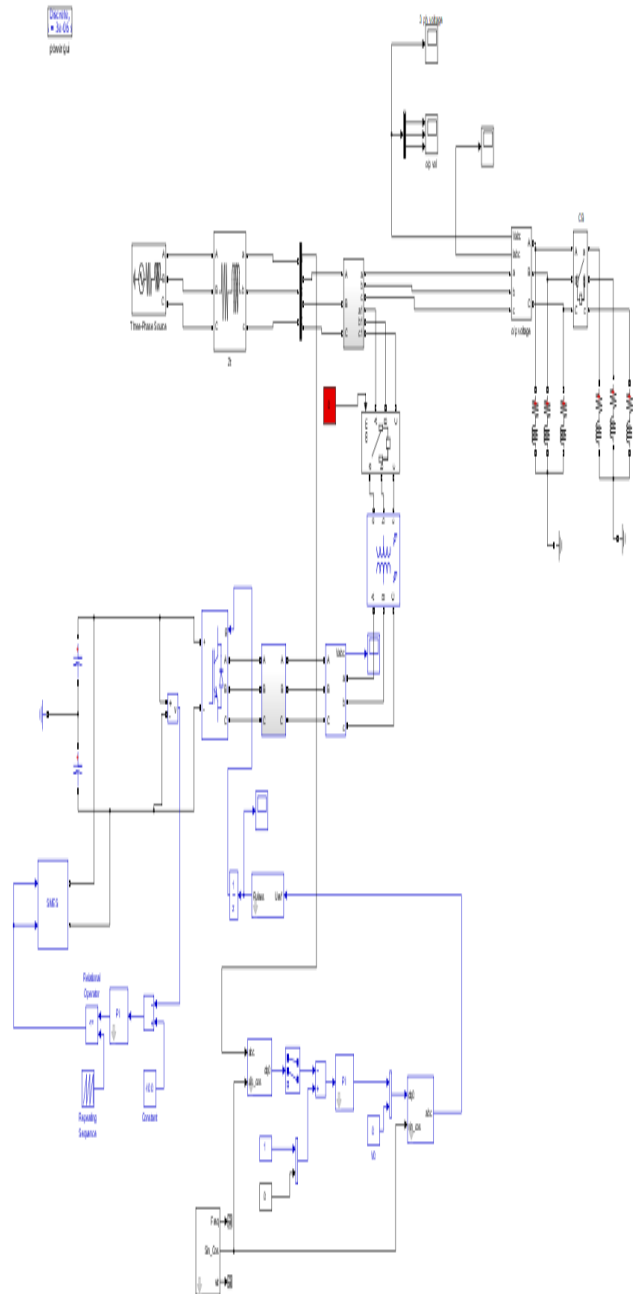

Fig.9. Simulink model of Matlab Circuit of SMES Based DVR system

Conclusion and Future Scope

Conclusion

It proposed a design of the Superconducting Magnetic Energy Storage module as a source of dc voltage to reduce voltage sag and swell to boost the power efficiency of a DVR-based distribution network. The simulation results show that the DVR based on SMES compensates for swelling and swelling rapidly and provides excellent voltage control in a balanced and unbalanced situation for the DVR without any difficulties and injects the appropriate voltage. The simulation shows DVR output in reducing voltage sag and swell is satisfactory.

Future Scope

- Other specialized Controllers Fuzzy controller, SVPWM Technology can be used with DVR to improve DVR performance in distribution networks.
- A new tool called Interline Dynamic Voltage Restorer (IDVR) will be addressed for the mitigation of power quality problems and the investigation of power system stability. This system is composed of two traditional DVRs mounted in two separate delivery feeders and the DC connection.

References

- [1].P. Boonchiam and N. Mithulananthan, —Understanding of Dynamic Voltage Restorers through MATLAB Simulation,|| Thammasat Int. J. Sc. Tech., Vol. 11, No. 3, July-Sept 2006.
- [2].M.H.Haque —Compensation of distribution system voltage sag by DVR and DSTATCOM|| Power Tech Proceedings, 2001 IEEE Porto, Volume: 1, 10-13 Sept.2001 Pages: 5 pp. vol.1.
- [3].IEEE Task Force on Benchmark Models for Digital Simulation of FACTS and Custom-Power Controllers, T&D Committee,|| Detailed Modeling of Superconducting Magnetic Energy Storage (SMES) System||, IEEE TRANSACTIONS ON POWER DELIVERY, VOL. 21, NO. 2, APRIL 2006.

- [4].Jianxun Jin and Xiaoyuan Chen, —HTS Inductive Magnetic Energy Storage with Power Control Technology.
- [5].H.P. Tiwari, Sunil Kumar Gupta ,||DVR Based On Fuel Cell: An Innovative Back-Up System, International Journal of Environmental Science and Development, Vol.1, No.1, April 2010, ISSN:2010-02.
- [6].J. S. Kim, S. H. Lim, J. C. Kim and J. F. Moon, “A Study on Bus Voltage Sag Considering the Impedance of SFCL and Fault Conditions in Power Distribution Systems,” IEEE Trans. Appl. Supercond., Vol. 23, No. 3, pp. 5601604-5601604, June 2013.
- [7].Z. X. Zheng, X. Y. Xiao, C. S. Li, Z. Chen and Y. Zhang, “Performance Evaluation of SMES System for Initial and Steady Voltage Sag Compensations,” IEEE Trans. Appl. Supercond., Vol. 26, No. 7, pp. 1-5, Oct. 2016.
- [8].Z. C. Zou, X. Y. Xiao, Y. F. Liu, Y. Zhang and Y. H. Wang, “Integrated protection of DFIG-based wind turbine with a resistive-type SFCL under symmetrical and asymmetrical faults,” IEEE Trans. Appl. Supercond., vol. 26, no. 7, Oct. 2016.